

MAIN RULES:

- Before starting read instructions carefully.
- The drives must turn in opposite directions to one another.
- Electric control shall avoid single vibrator turn.

WORKING PARAMETERS:

Clarence to static parts.....50 mm
 Working frequency.....1200 r.p.m.
 Total static load.....1600 kg.
 Total dynamic load.....280 daN.

CABINET, SIREN AND
 BEACON IN THE BACK
 OF THE MACHINE

Hopper 1,6m³

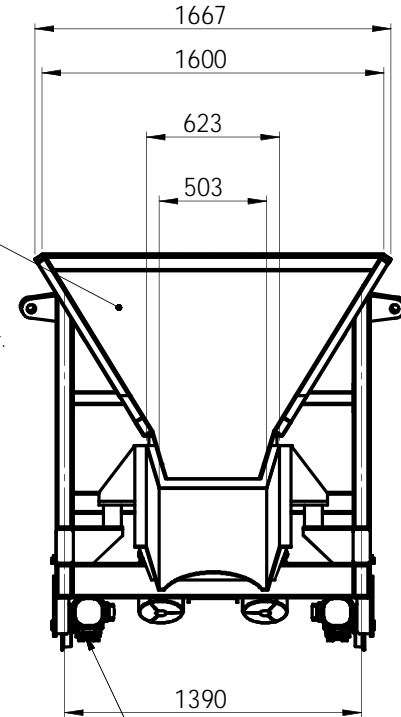

Rails S/P 105.481

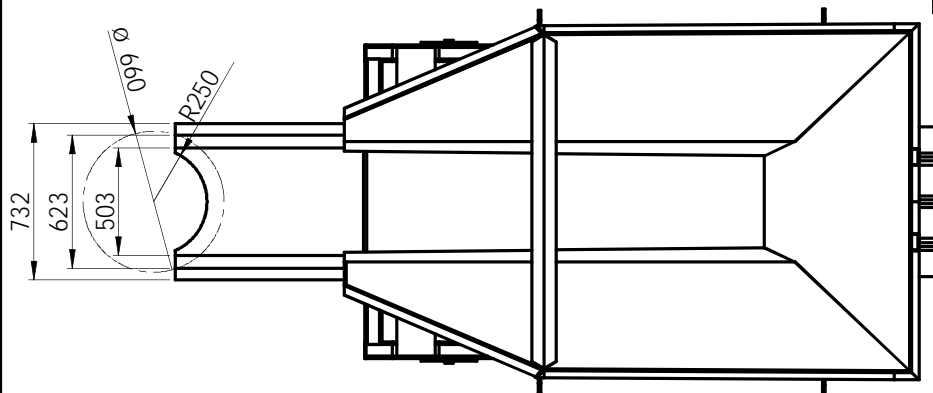
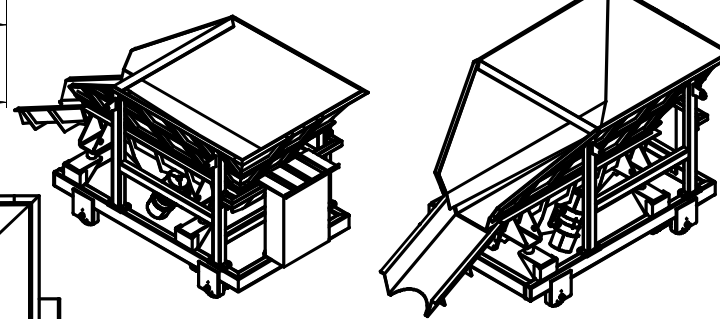

REV.	DESCRIPTION	DATA	APPROVED
R01	We add the top view	17-07-2012	E.Sardon
SCALE	MATERIAL	Replacing:	Replaced by:
1: 25			
A3	WEIGHT (kg)	CARGADOR RBA 50-62/280	
Sheet 1/1		1013300784	CODE
		105463	DRAWING REV.
			R01
	URBAR ingenieros s.a.		HORNOS Y METALES S.A.
		Projection	Drw. E.Sardon 11/07/2012
		Not specified tolerances DIN 7168 average rating	Rev. I.Paino 11/07/2012
			Aprob. Baena 11/07/2012